

Lenkrolle mit Totalfeststeller nachlaufend:

KSF2-41C-P100 (VIVAX 2.0)

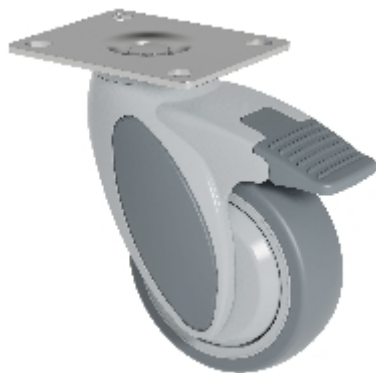

Technische Daten

Durchmesser		100 mm
Radbreite		32 mm
Bauhöhe		142,5 mm
Ausladung		46 mm
Plattengröße		100x80 mm
Schraublochdurchmesser		9 mm
Schraublochentfernung		80x60/76x55 mm
Tragkraft		100 kg
Gewicht		620 g

Technische Beschreibung

Kunststoffrolle

Gabel aus hochfestem schlagzähem Nylon

Lenkgabelkopf mit abgedichtetem Rillenkugellager



Rad

Polypropylen-Radkörper

thermoplastische Bandage (TPE, Shore A 87)

Fadenschutz

Kugellager

nicht auselend